

Fragebogen

1 General_Instruction



GEORG-AUGUST-UNIVERSITÄT
GÖTTINGEN

Dear participant,

thank you for choosing to participate in this study!

Purpose of the study:

The aim of this study is to investigate how people reason about causality in specific scenarios. The study is conducted by the Georg-Elias-Müller Institute of Psychology at the Georg-August University of Göttingen. The person responsible for the study is Dr. Simon Stephan, Department of Cognitive Decision and Sciences, University of Göttingen (simon.stephan@psych.uni-goettingen.de).

Procedure and duration of the study:

The study takes about 3 minutes to complete. We will first show you a fictitious scenario and then ask you some test questions that we'd like you to answer based on your intuitive understanding of the scenario.

Termination of study participation:

You can terminate the study at any time, without giving reasons. Please note, however, that we can only evaluate your results if you have participated in the entire study.

Risks:

There are no risks associated with participation.

Data protection:

The recorded data is collected anonymously, i.e. we can not identify who the data originates from. Individual data will not be passed on. The data protection guidelines are strictly observed. You can object to the further processing of your data and request their deletion at any time by contacting us through Prolific.

Thank you for your time!

I hereby declare that I have been informed in writing of the nature of the scientific investigation. I have read the preceding information carefully. I am aware that I can withdraw my consent at any time without giving reasons and without detrimental consequences for me and that I can object to the further processing of my data at any time during the investigation and demand their deletion or destruction. I am willing to participate in the scientific investigation. I have the right to ask questions concerning the study at any time to the person responsible, Dr. Simon Stephan (simon.stephan@psych.uni-goettingen.de).

If you agree, you can continue with this study.

Before you start, please:

- maximize your browser window;

- switch off phone/e-mail/music & anything else distracting

- and please enter your Prolific ID [it can be found at the top of this webpage or when going to your account info]:

2 Confirmations

This study works properly only on Desktop PCs and Laptops, and not on Smartphones or Tablets. Please confirm that you take part via Desktop PC or Laptop.

- I confirm that I take part via Desktop PC or Laptop.
- I do not confirm that I take part via Desktop PC or Laptop.

For the scientific utility of the results, it is very important that you provide complete and careful responses.

How seriously will you take your participation in the study?

- I confirm that I will take my participation in this study seriously.
- I confirm that I will not take my participation in this study seriously.

3.1.1 scenario

Please read the following information:

Below you see three independent electrical set-ups, A, B, and C. All consist of a "switch box" (left box with red button) that can be connected to up to three LED lights. Flipping a red switch from "off" to "on" causes the LEDs connected to the switch box to turn from "off" to "on".

Switch box A is connected to three LEDs. Switch box B is connected to one LED. Switch box C is not connected to any LED.

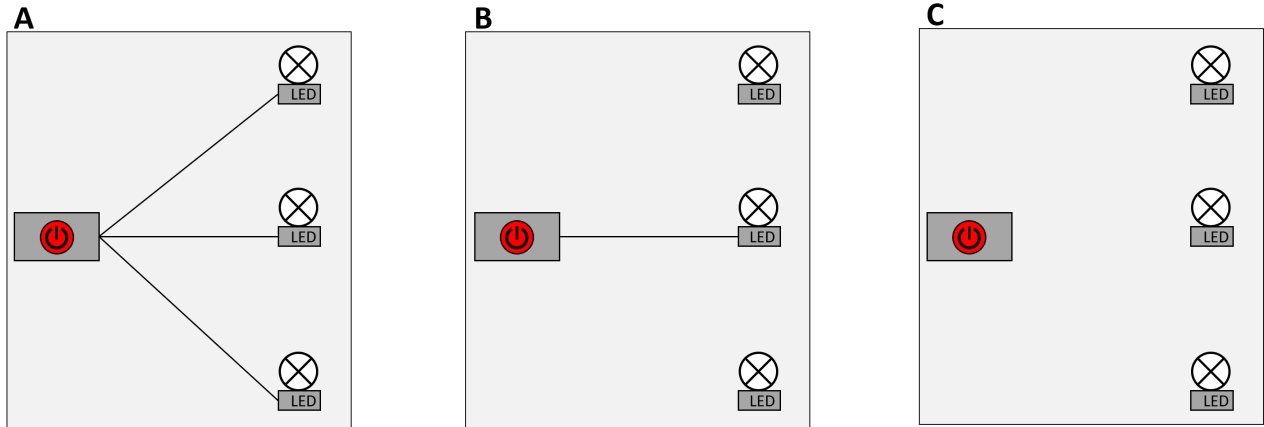

If you've studied the given information thoroughly, please answer the following questions:

If the red switch of box A is flipped from "off" to "on", how likely will this cause the middle LED to turn on?

Please use the scale below to provide your answer.

If the red switch of box B is flipped from "off" to "on", how likely will this cause the middle LED to turn on?

Please use the scale below to provide your answer.

If the red switch of box C is flipped from "off" to "on", how likely will this cause the middle LED to turn on?

Please use the scale below to provide your answer.

3.2.1 scenario

Please read the following information:

Below you see three independent electrical set-ups, A, B, and C. All consist of a "switch box" (left box with red button) that can be connected to up to three LED lights. Flipping a red switch from "off" to "on" causes the LEDs connected to the switch box to turn from "off" to "on".

Switch box A is connected to three LEDs. Switch box B is connected to one LED. Switch box C is not connected to any LED.

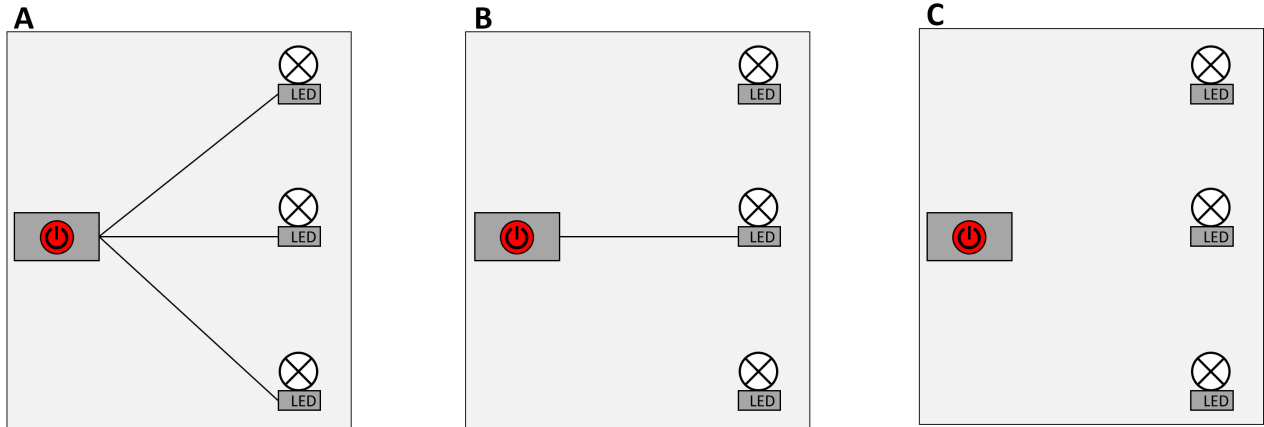

If you've studied the given information thoroughly, please answer the following questions:

If the red switch of box A is flipped from "off" to "on", how likely will this cause the middle LED to turn on?

Please use the scale below to provide your answer.

If the red switch of box C is flipped from "off" to "on", how likely will this cause the middle LED to turn on?

Please use the scale below to provide your answer.

If the red switch of box B is flipped from "off" to "on", how likely will this cause the middle LED to turn on?

Please use the scale below to provide your answer.

3.3.1 scenario

Please read the following information:

Below you see three independent electrical set-ups, A, B, and C. All consist of a "switch box" (left box with red button) that can be connected to up to three LED lights. Flipping a red switch from "off" to "on" causes the LEDs connected to the switch box to turn from "off" to "on".

Switch box A is connected to three LEDs. Switch box B is connected to one LED. Switch box C is not connected to any LED.

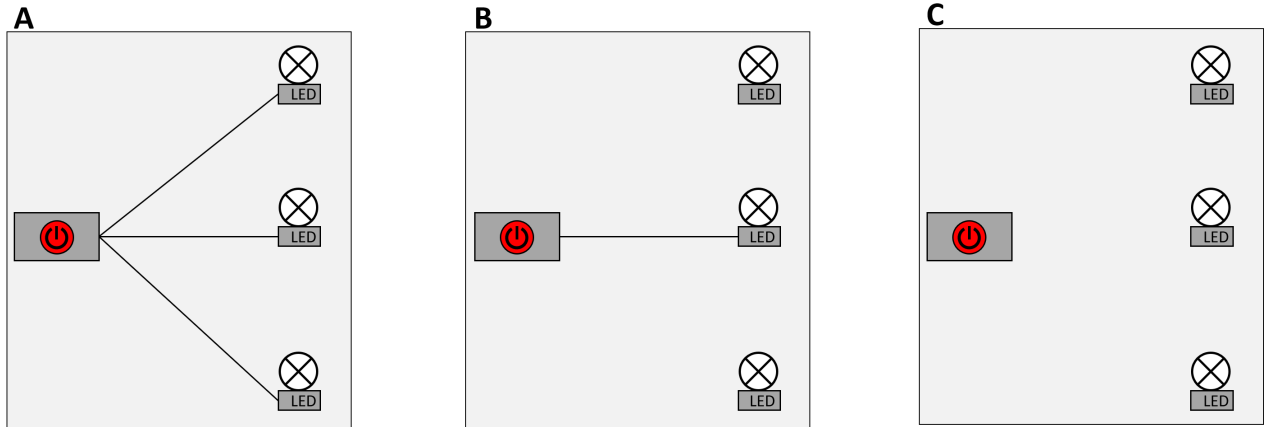

If you've studied the given information thoroughly, please answer the following questions:

If the red switch of box B is flipped from "off" to "on", how likely will this cause the middle LED to turn on?

Please use the scale below to provide your answer.

If the red switch of box A is flipped from "off" to "on", how likely will this cause the middle LED to turn on?

Please use the scale below to provide your answer.

If the red switch of box C is flipped from "off" to "on", how likely will this cause the middle LED to turn on?

Please use the scale below to provide your answer.

3.4.1 scenario

Please read the following information:

Below you see three independent electrical set-ups, A, B, and C. All consist of a "switch box" (left box with red button) that can be connected to up to three LED lights. Flipping a red switch from "off" to "on" causes the LEDs connected to the switch box to turn from "off" to "on".

Switch box A is connected to three LEDs. Switch box B is connected to one LED. Switch box C is not connected to any LED.

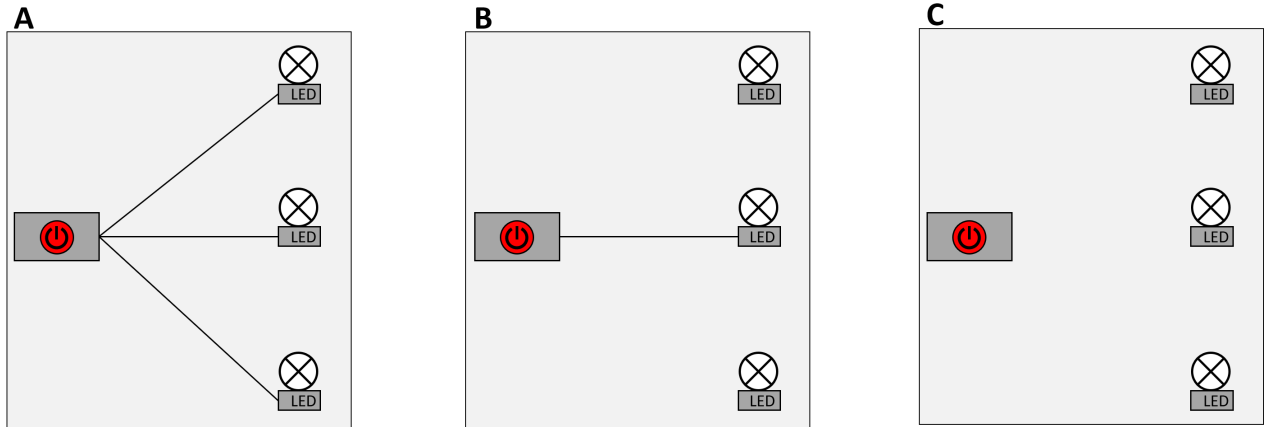

If you've studied the given information thoroughly, please answer the following questions:

If the red switch of box B is flipped from "off" to "on", how likely will this cause the middle LED to turn on?

Please use the scale below to provide your answer.

If the red switch of box C is flipped from "off" to "on", how likely will this cause the middle LED to turn on?

Please use the scale below to provide your answer.

If the red switch of box A is flipped from "off" to "on", how likely will this cause the middle LED to turn on?

Please use the scale below to provide your answer.

3.5.1 scenario

Please read the following information:

Below you see three independent electrical set-ups, A, B, and C. All consist of a "switch box" (left box with red button) that can be connected to up to three LED lights. Flipping a red switch from "off" to "on" causes the LEDs connected to the switch box to turn from "off" to "on".

Switch box A is connected to three LEDs. Switch box B is connected to one LED. Switch box C is not connected to any LED.

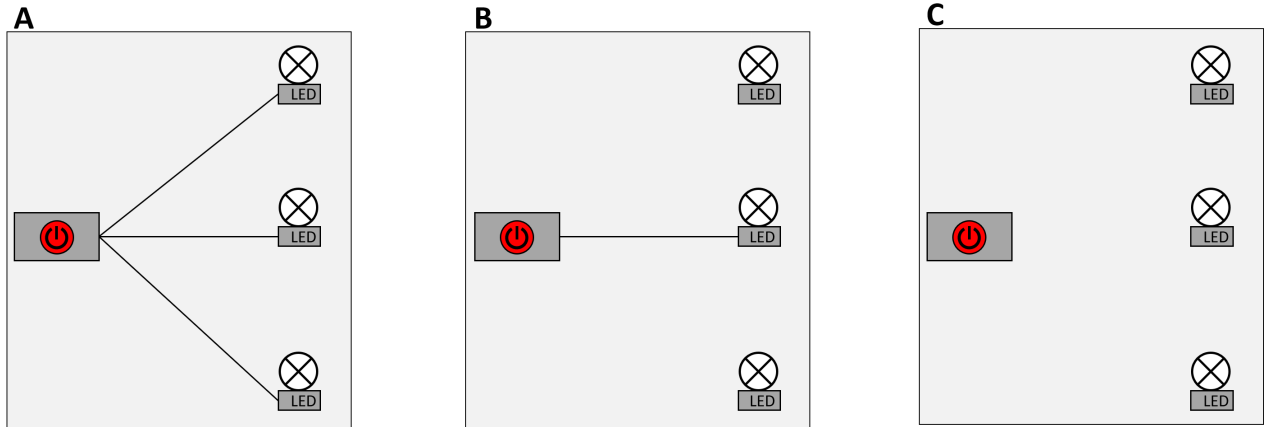

If you've studied the given information thoroughly, please answer the following questions:

If the red switch of box C is flipped from "off" to "on", how likely will this cause the middle LED to turn on?

Please use the scale below to provide your answer.

If the red switch of box A is flipped from "off" to "on", how likely will this cause the middle LED to turn on?

Please use the scale below to provide your answer.

If the red switch of box B is flipped from "off" to "on", how likely will this cause the middle LED to turn on?

Please use the scale below to provide your answer.

3.6.1 scenario

Please read the following information:

Below you see three independent electrical set-ups, A, B, and C. All consist of a "switch box" (left box with red button) that can be connected to up to three LED lights. Flipping a red switch from "off" to "on" causes the LEDs connected to the switch box to turn from "off" to "on".

Switch box A is connected to three LEDs. Switch box B is connected to one LED. Switch box C is not connected to any LED.

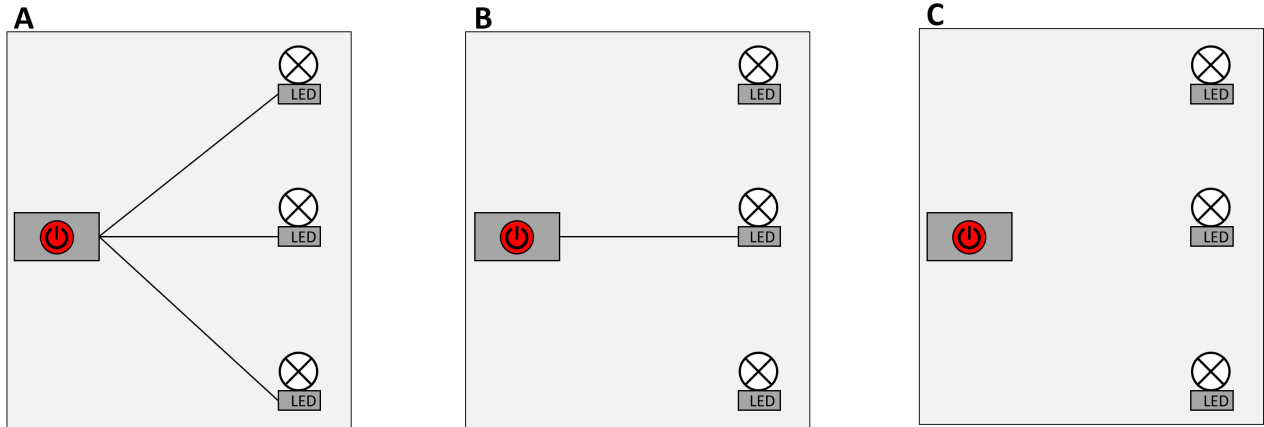

If you've studied the given information thoroughly, please answer the following questions:

If the red switch of box C is flipped from "off" to "on", how likely will this cause the middle LED to turn on?

Please use the scale below to provide your answer.

If the red switch of box B is flipped from "off" to "on", how likely will this cause the middle LED to turn on?

Please use the scale below to provide your answer.

If the red switch of box A is flipped from "off" to "on", how likely will this cause the middle LED to turn on?

Please use the scale below to provide your answer.

4.1.1 scenario

Please read the following information:

Below you see three independent electrical set-ups, A, B, and C. All consist of a "switch box" (left box with red button) that can be connected to up to three LED lights. Flipping a red switch from "off" to "on" causes the LEDs connected to the switch box to turn from "off" to "on".

Switch box A is connected to three LEDs. Switch box B is not connected to any LED. Switch box C is connected to one LED.

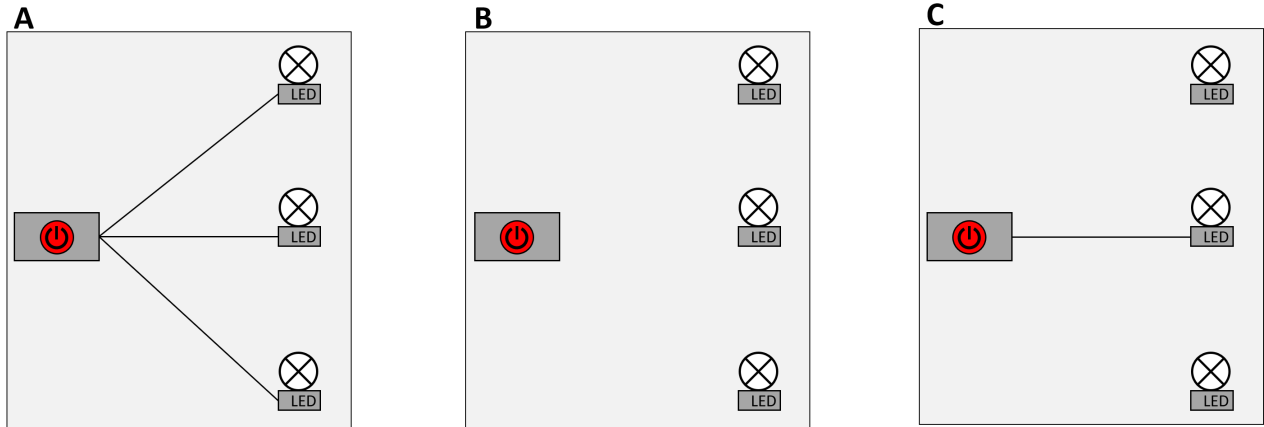

If you've studied the given information thoroughly, please answer the following questions:

If the red switch of box A is flipped from "off" to "on", how likely will this cause the middle LED to turn on?

Please use the scale below to provide your answer.

If the red switch of box C is flipped from "off" to "on", how likely will this cause the middle LED to turn on?

Please use the scale below to provide your answer.

If the red switch of box B is flipped from "off" to "on", how likely will this cause the middle LED to turn on?

Please use the scale below to provide your answer.

4.2.1 scenario

Please read the following information:

Below you see three independent electrical set-ups, A, B, and C. All consist of a "switch box" (left box with red button) that can be connected to up to three LED lights. Flipping a red switch from "off" to "on" causes the LEDs connected to the switch box to turn from "off" to "on".

Switch box A is connected to three LEDs. Switch box B is not connected to any LED. Switch box C is connected to one LED.

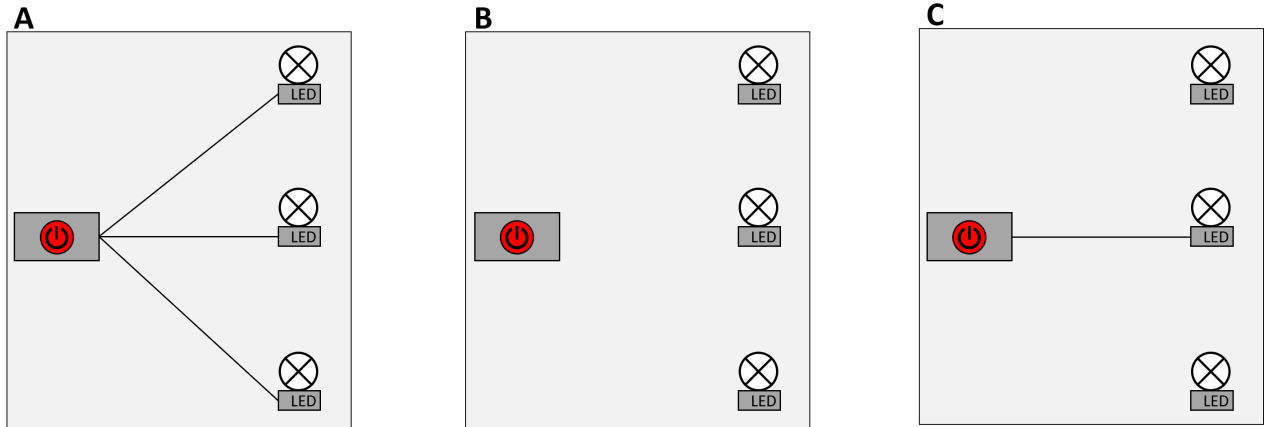

If you've studied the given information thoroughly, please answer the following questions:

If the red switch of box A is flipped from "off" to "on", how likely will this cause the middle LED to turn on?

Please use the scale below to provide your answer.

If the red switch of box B is flipped from "off" to "on", how likely will this cause the middle LED to turn on?

Please use the scale below to provide your answer.

If the red switch of box C is flipped from "off" to "on", how likely will this cause the middle LED to turn on?

Please use the scale below to provide your answer.

4.3.1 scenario

Please read the following information:

Below you see three independent electrical set-ups, A, B, and C. All consist of a "switch box" (left box with red button) that can be connected to up to three LED lights. Flipping a red switch from "off" to "on" causes the LEDs connected to the switch box to turn from "off" to "on".

Switch box A is connected to three LEDs. Switch box B is not connected to any LED. Switch box C is connected to one LED.

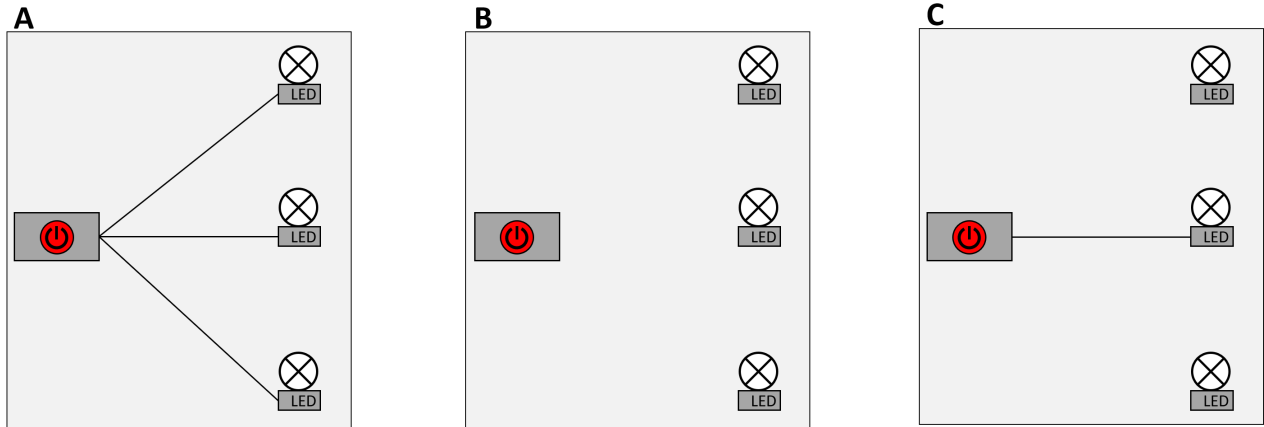

If you've studied the given information thoroughly, please answer the following questions:

If the red switch of box C is flipped from "off" to "on", how likely will this cause the middle LED to turn on?

Please use the scale below to provide your answer.

If the red switch of box A is flipped from "off" to "on", how likely will this cause the middle LED to turn on?

Please use the scale below to provide your answer.

If the red switch of box B is flipped from "off" to "on", how likely will this cause the middle LED to turn on?

Please use the scale below to provide your answer.

4.4.1 scenario

Please read the following information:

Below you see three independent electrical set-ups, A, B, and C. All consist of a "switch box" (left box with red button) that can be connected to up to three LED lights. Flipping a red switch from "off" to "on" causes the LEDs connected to the switch box to turn from "off" to "on".

Switch box A is connected to three LEDs. Switch box B is not connected to any LED. Switch box C is connected to one LED.

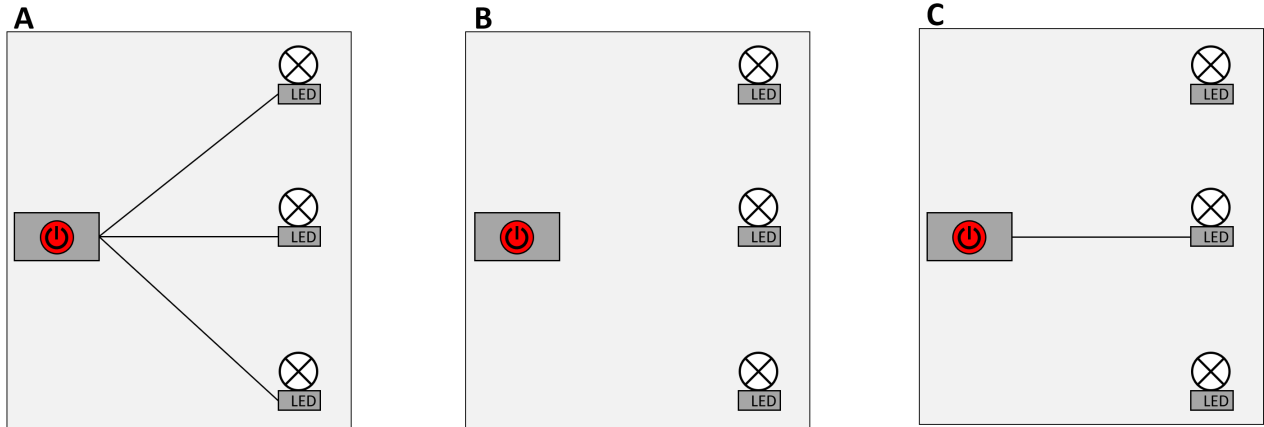

If you've studied the given information thoroughly, please answer the following questions:

If the red switch of box C is flipped from "off" to "on", how likely will this cause the middle LED to turn on?

Please use the scale below to provide your answer.

If the red switch of box B is flipped from "off" to "on", how likely will this cause the middle LED to turn on?

Please use the scale below to provide your answer.

If the red switch of box A is flipped from "off" to "on", how likely will this cause the middle LED to turn on?

Please use the scale below to provide your answer.

4.5.1 scenario

Please read the following information:

Below you see three independent electrical set-ups, A, B, and C. All consist of a "switch box" (left box with red button) that can be connected to up to three LED lights. Flipping a red switch from "off" to "on" causes the LEDs connected to the switch box to turn from "off" to "on".

Switch box A is connected to three LEDs. Switch box B is not connected to any LED. Switch box C is connected to one LED.

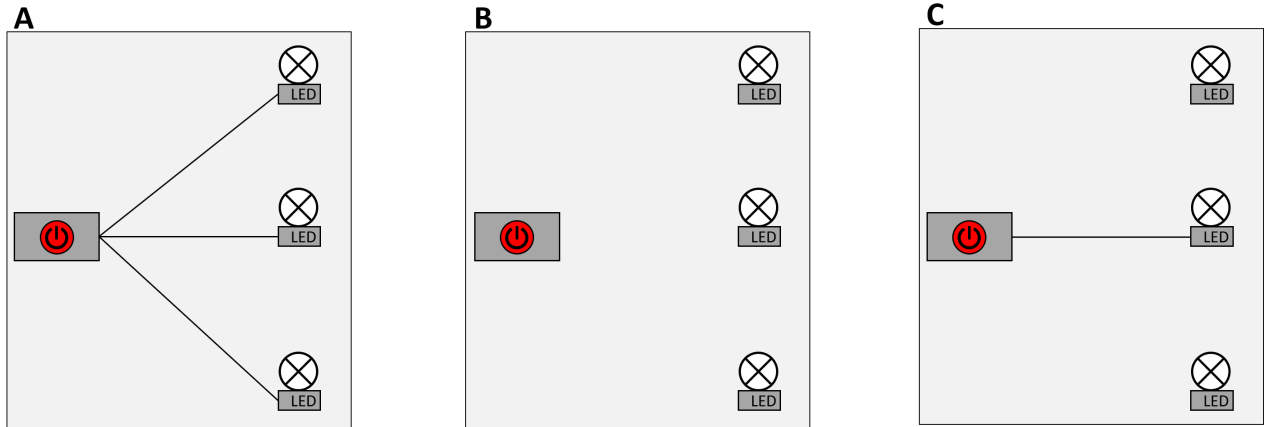

If you've studied the given information thoroughly, please answer the following questions:

If the red switch of box B is flipped from "off" to "on", how likely will this cause the middle LED to turn on?

Please use the scale below to provide your answer.

If the red switch of box A is flipped from "off" to "on", how likely will this cause the middle LED to turn on?

Please use the scale below to provide your answer.

If the red switch of box C is flipped from "off" to "on", how likely will this cause the middle LED to turn on?

Please use the scale below to provide your answer.

4.6.1 scenario

Please read the following information:

Below you see three independent electrical set-ups, A, B, and C. All consist of a "switch box" (left box with red button) that can be connected to up to three LED lights. Flipping a red switch from "off" to "on" causes the LEDs connected to the switch box to turn from "off" to "on".

Switch box A is connected to three LEDs. Switch box B is not connected to any LED. Switch box C is connected to one LED.

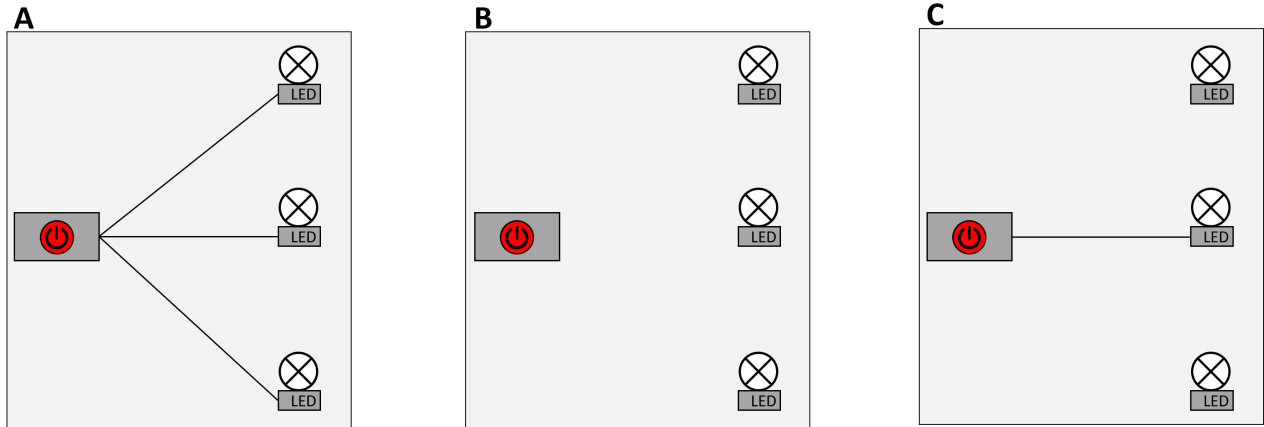

If you've studied the given information thoroughly, please answer the following questions:

If the red switch of box B is flipped from "off" to "on", how likely will this cause the middle LED to turn on?

Please use the scale below to provide your answer.

If the red switch of box C is flipped from "off" to "on", how likely will this cause the middle LED to turn on?

Please use the scale below to provide your answer.

If the red switch of box A is flipped from "off" to "on", how likely will this cause the middle LED to turn on?

Please use the scale below to provide your answer.

5.1.1 scenario

Please read the following information:

Below you see three independent electrical set-ups, A, B, and C. All consist of a "switch box" (left box with red button) that can be connected to up to three LED lights. Flipping a red switch from "off" to "on" causes the LEDs connected to the switch box to turn from "off" to "on".

Switch box A is connected to one LED. Switch box B is connected to three LEDs. Switch box C is not connected to any LED.

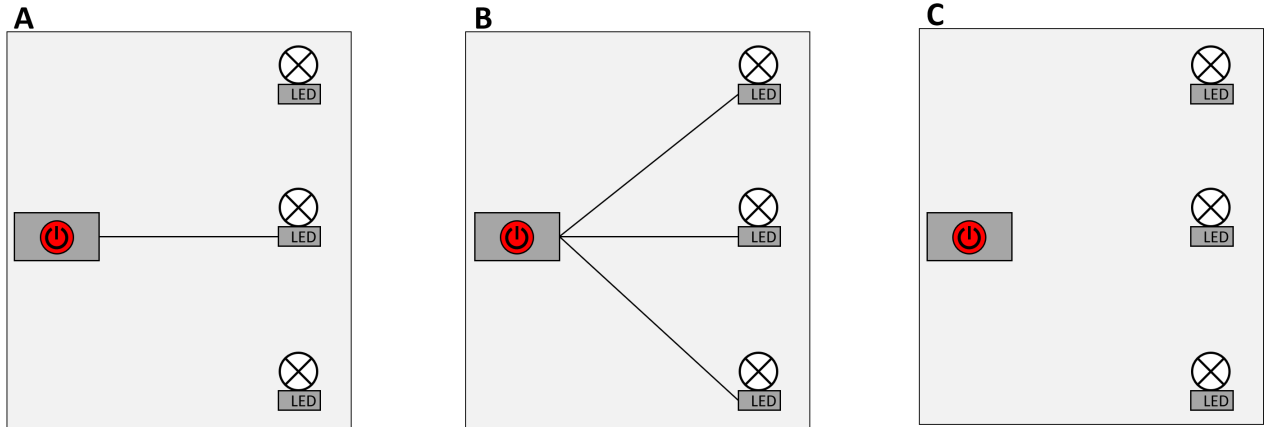

If you've studied the given information thoroughly, please answer the following questions:

If the red switch of box B is flipped from "off" to "on", how likely will this cause the middle LED to turn on?

Please use the scale below to provide your answer.

If the red switch of box A is flipped from "off" to "on", how likely will this cause the middle LED to turn on?

Please use the scale below to provide your answer.

If the red switch of box C is flipped from "off" to "on", how likely will this cause the middle LED to turn on?

Please use the scale below to provide your answer.

5.2.1 scenario

Please read the following information:

Below you see three independent electrical set-ups, A, B, and C. All consist of a "switch box" (left box with red button) that can be connected to up to three LED lights. Flipping a red switch from "off" to "on" causes the LEDs connected to the switch box to turn from "off" to "on".

Switch box A is connected to one LED. Switch box B is connected to three LEDs. Switch box C is not connected to any LED.

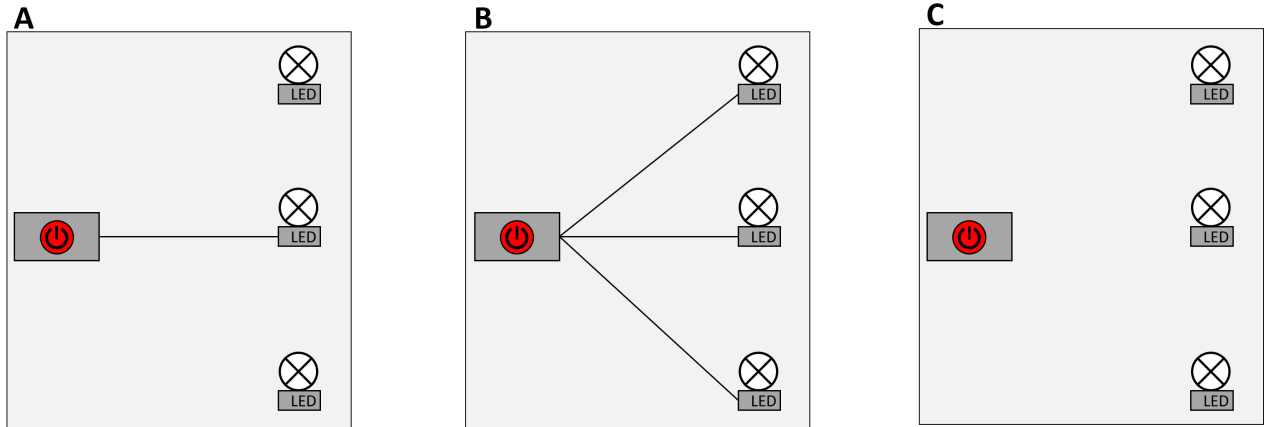

If you've studied the given information thoroughly, please answer the following questions:

If the red switch of box B is flipped from "off" to "on", how likely will this cause the middle LED to turn on?

Please use the scale below to provide your answer.

If the red switch of box C is flipped from "off" to "on", how likely will this cause the middle LED to turn on?

Please use the scale below to provide your answer.

If the red switch of box A is flipped from "off" to "on", how likely will this cause the middle LED to turn on?

Please use the scale below to provide your answer.

5.3.1 scenario

Please read the following information:

Below you see three independent electrical set-ups, A, B, and C. All consist of a "switch box" (left box with red button) that can be connected to up to three LED lights. Flipping a red switch from "off" to "on" causes the LEDs connected to the switch box to turn from "off" to "on".

Switch box A is connected to one LED. Switch box B is connected to three LEDs. Switch box C is not connected to any LED.

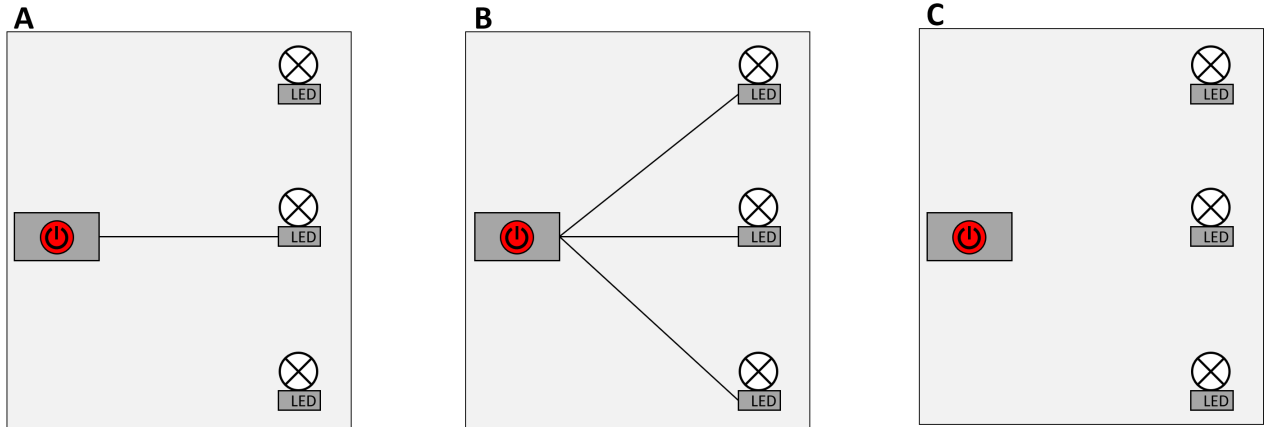

If you've studied the given information thoroughly, please answer the following questions:

If the red switch of box A is flipped from "off" to "on", how likely will this cause the middle LED to turn on?

Please use the scale below to provide your answer.

If the red switch of box B is flipped from "off" to "on", how likely will this cause the middle LED to turn on?

Please use the scale below to provide your answer.

If the red switch of box C is flipped from "off" to "on", how likely will this cause the middle LED to turn on?

Please use the scale below to provide your answer.

5.4.1 scenario

Please read the following information:

Below you see three independent electrical set-ups, A, B, and C. All consist of a "switch box" (left box with red button) that can be connected to up to three LED lights. Flipping a red switch from "off" to "on" causes the LEDs connected to the switch box to turn from "off" to "on".

Switch box A is connected to one LED. Switch box B is connected to three LEDs. Switch box C is not connected to any LED.

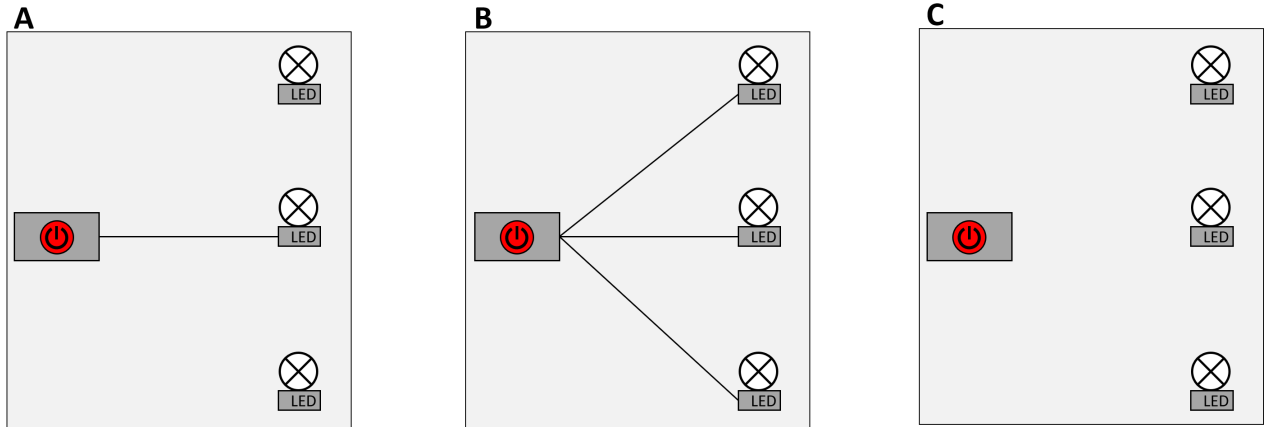

If you've studied the given information thoroughly, please answer the following questions:

If the red switch of box A is flipped from "off" to "on", how likely will this cause the middle LED to turn on?

Please use the scale below to provide your answer.

If the red switch of box C is flipped from "off" to "on", how likely will this cause the middle LED to turn on?

Please use the scale below to provide your answer.

If the red switch of box B is flipped from "off" to "on", how likely will this cause the middle LED to turn on?

Please use the scale below to provide your answer.

5.5.1 scenario

Please read the following information:

Below you see three independent electrical set-ups, A, B, and C. All consist of a "switch box" (left box with red button) that can be connected to up to three LED lights. Flipping a red switch from "off" to "on" causes the LEDs connected to the switch box to turn from "off" to "on".

Switch box A is connected to one LED. Switch box B is connected to three LEDs. Switch box C is not connected to any LED.

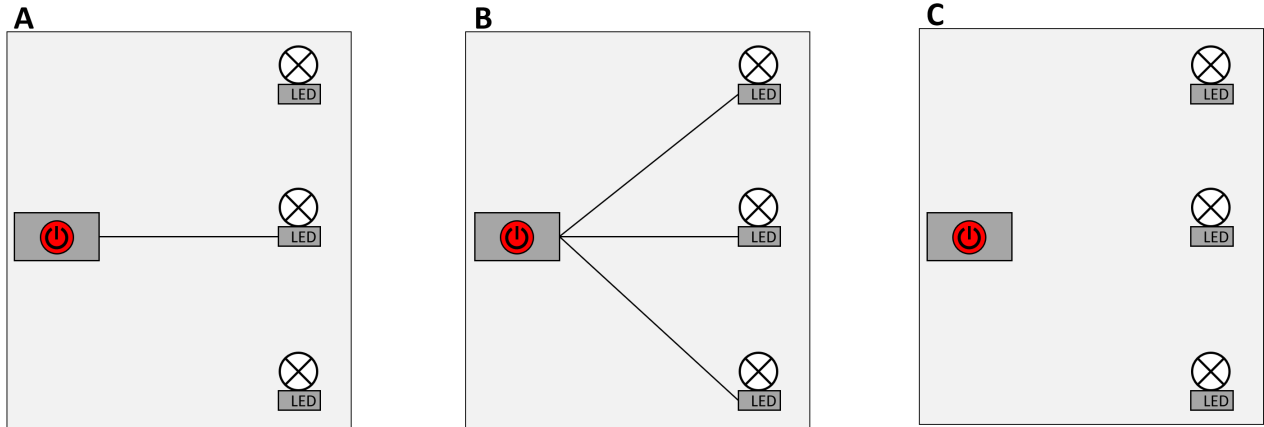

If you've studied the given information thoroughly, please answer the following questions:

If the red switch of box C is flipped from "off" to "on", how likely will this cause the middle LED to turn on?

Please use the scale below to provide your answer.

If the red switch of box B is flipped from "off" to "on", how likely will this cause the middle LED to turn on?

Please use the scale below to provide your answer.

If the red switch of box A is flipped from "off" to "on", how likely will this cause the middle LED to turn on?

Please use the scale below to provide your answer.

5.6.1 scenario

Please read the following information:

Below you see three independent electrical set-ups, A, B, and C. All consist of a "switch box" (left box with red button) that can be connected to up to three LED lights. Flipping a red switch from "off" to "on" causes the LEDs connected to the switch box to turn from "off" to "on".

Switch box A is connected to one LED. Switch box B is connected to three LEDs. Switch box C is not connected to any LED.

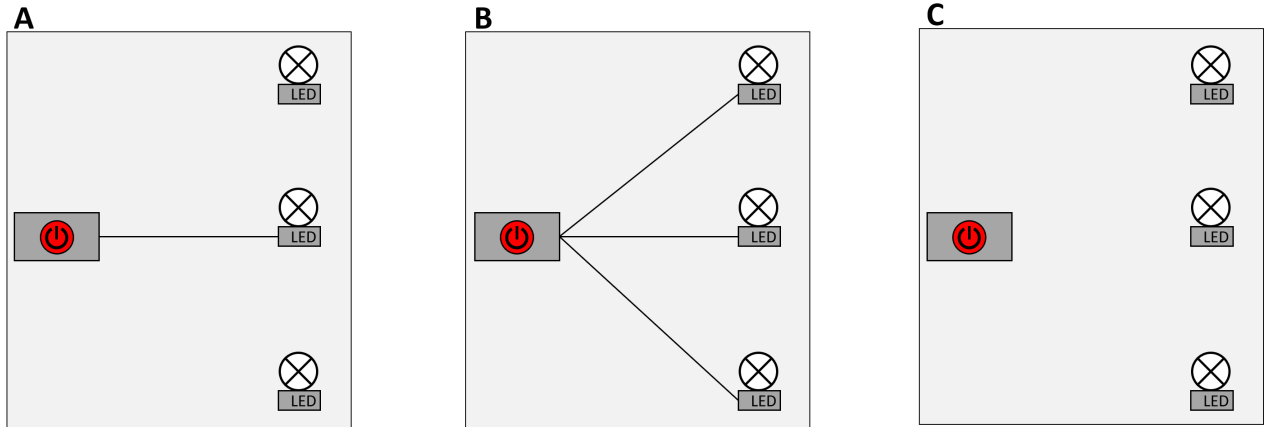

If you've studied the given information thoroughly, please answer the following questions:

If the red switch of box C is flipped from "off" to "on", how likely will this cause the middle LED to turn on?

Please use the scale below to provide your answer.

If the red switch of box A is flipped from "off" to "on", how likely will this cause the middle LED to turn on?

Please use the scale below to provide your answer.

If the red switch of box B is flipped from "off" to "on", how likely will this cause the middle LED to turn on?

Please use the scale below to provide your answer.

6.1.1 scenario

Please read the following information:

Below you see three independent electrical set-ups, A, B, and C. All consist of a "switch box" (left box with red button) that can be connected to up to three LED lights. Flipping a red switch from "off" to "on" causes the LEDs connected to the switch box to turn from "off" to "on".

Switch box A is connected to one LED. Switch box B is not connected to any LED. Switch box C is connected to three LEDs.

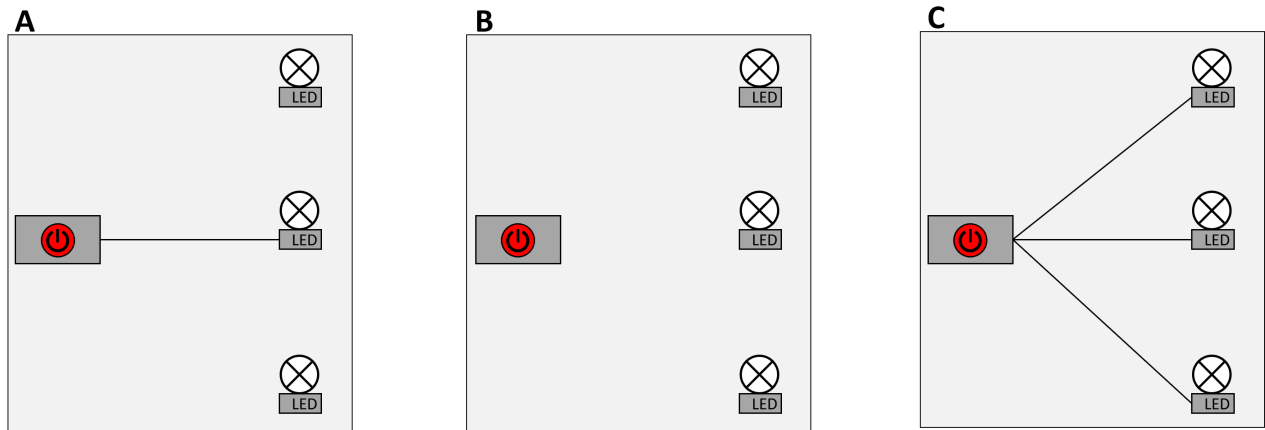

If you've studied the given information thoroughly, please answer the following questions:

If the red switch of box C is flipped from "off" to "on", how likely will this cause the middle LED to turn on?

Please use the scale below to provide your answer.

If the red switch of box A is flipped from "off" to "on", how likely will this cause the middle LED to turn on?

Please use the scale below to provide your answer.

If the red switch of box B is flipped from "off" to "on", how likely will this cause the middle LED to turn on?

Please use the scale below to provide your answer.

6.2.1 scenario

Please read the following information:

Below you see three independent electrical set-ups, A, B, and C. All consist of a "switch box" (left box with red button) that can be connected to up to three LED lights. Flipping a red switch from "off" to "on" causes the LEDs connected to the switch box to turn from "off" to "on".

Switch box A is connected to one LED. Switch box B is not connected to any LED. Switch box C is connected to three LEDs.

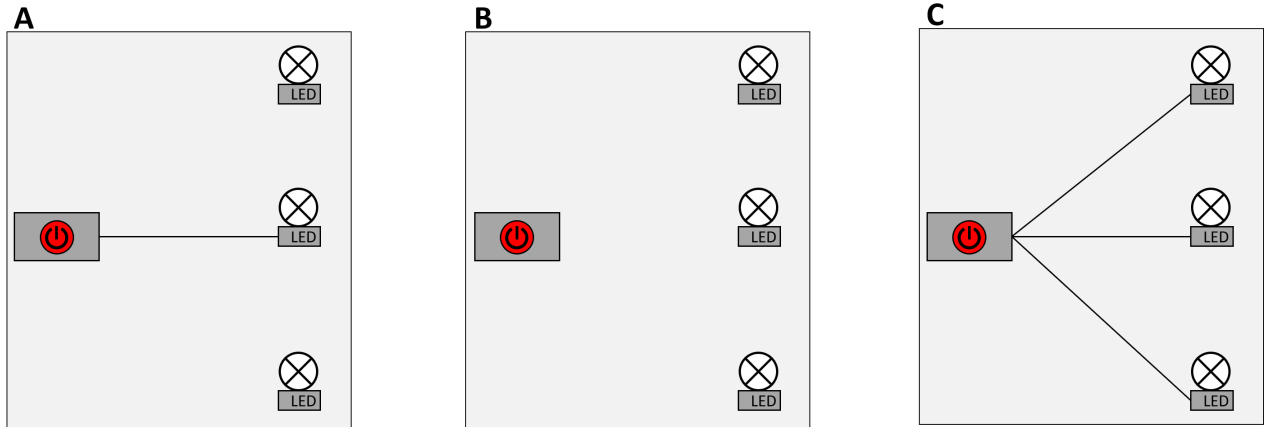

If you've studied the given information thoroughly, please answer the following questions:

If the red switch of box C is flipped from "off" to "on", how likely will this cause the middle LED to turn on?

Please use the scale below to provide your answer.

If the red switch of box B is flipped from "off" to "on", how likely will this cause the middle LED to turn on?

Please use the scale below to provide your answer.

If the red switch of box A is flipped from "off" to "on", how likely will this cause the middle LED to turn on?

Please use the scale below to provide your answer.

6.3.1 scenario

Please read the following information:

Below you see three independent electrical set-ups, A, B, and C. All consist of a "switch box" (left box with red button) that can be connected to up to three LED lights. Flipping a red switch from "off" to "on" causes the LEDs connected to the switch box to turn from "off" to "on".

Switch box A is connected to one LED. Switch box B is not connected to any LED. Switch box C is connected to three LEDs.

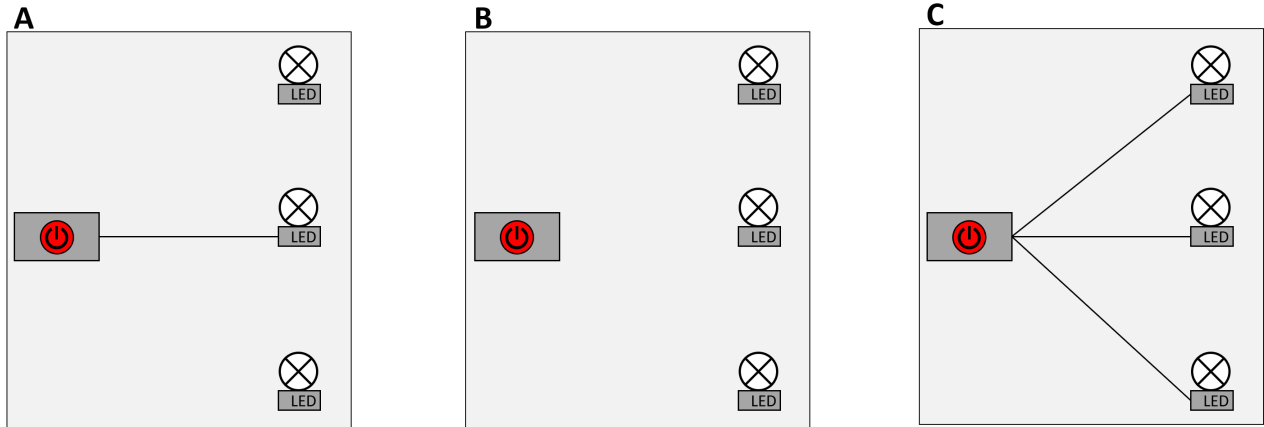

If you've studied the given information thoroughly, please answer the following questions:

If the red switch of box A is flipped from "off" to "on", how likely will this cause the middle LED to turn on?

Please use the scale below to provide your answer.

If the red switch of box C is flipped from "off" to "on", how likely will this cause the middle LED to turn on?

Please use the scale below to provide your answer.

If the red switch of box B is flipped from "off" to "on", how likely will this cause the middle LED to turn on?

Please use the scale below to provide your answer.

6.4.1 scenario

Please read the following information:

Below you see three independent electrical set-ups, A, B, and C. All consist of a "switch box" (left box with red button) that can be connected to up to three LED lights. Flipping a red switch from "off" to "on" causes the LEDs connected to the switch box to turn from "off" to "on".

Switch box A is connected to one LED. Switch box B is not connected to any LED. Switch box C is connected to three LEDs.

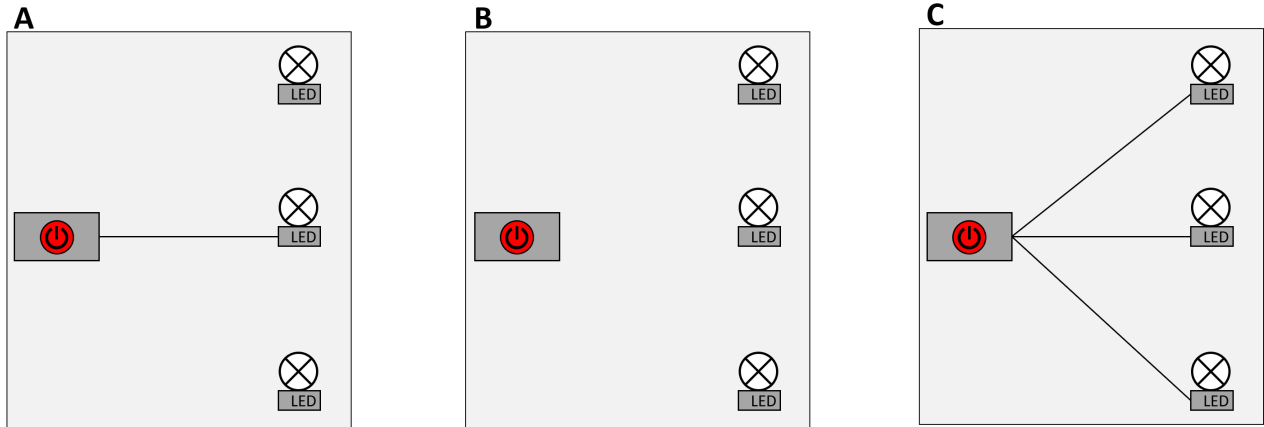

If you've studied the given information thoroughly, please answer the following questions:

If the red switch of box A is flipped from "off" to "on", how likely will this cause the middle LED to turn on?

Please use the scale below to provide your answer.

If the red switch of box B is flipped from "off" to "on", how likely will this cause the middle LED to turn on?

Please use the scale below to provide your answer.

If the red switch of box C is flipped from "off" to "on", how likely will this cause the middle LED to turn on?

Please use the scale below to provide your answer.

6.5.1 scenario

Please read the following information:

Below you see three independent electrical set-ups, A, B, and C. All consist of a "switch box" (left box with red button) that can be connected to up to three LED lights. Flipping a red switch from "off" to "on" causes the LEDs connected to the switch box to turn from "off" to "on".

Switch box A is connected to one LED. Switch box B is not connected to any LED. Switch box C is connected to three LEDs.

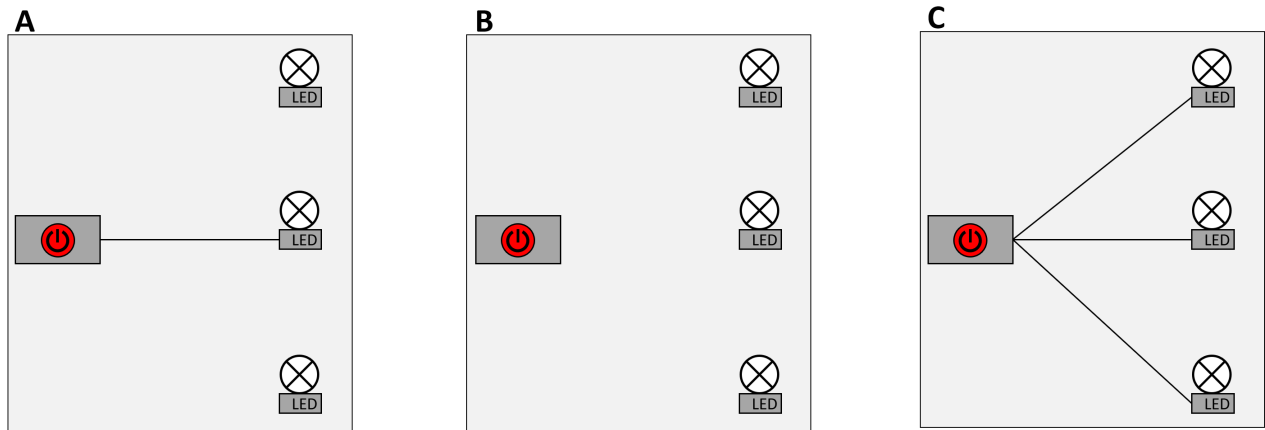

If you've studied the given information thoroughly, please answer the following questions:

If the red switch of box B is flipped from "off" to "on", how likely will this cause the middle LED to turn on?

Please use the scale below to provide your answer.

If the red switch of box C is flipped from "off" to "on", how likely will this cause the middle LED to turn on?

Please use the scale below to provide your answer.

If the red switch of box A is flipped from "off" to "on", how likely will this cause the middle LED to turn on?

Please use the scale below to provide your answer.

6.6.1 scenario

Please read the following information:

Below you see three independent electrical set-ups, A, B, and C. All consist of a "switch box" (left box with red button) that can be connected to up to three LED lights. Flipping a red switch from "off" to "on" causes the LEDs connected to the switch box to turn from "off" to "on".

Switch box A is connected to one LED. Switch box B is not connected to any LED. Switch box C is connected to three LEDs.

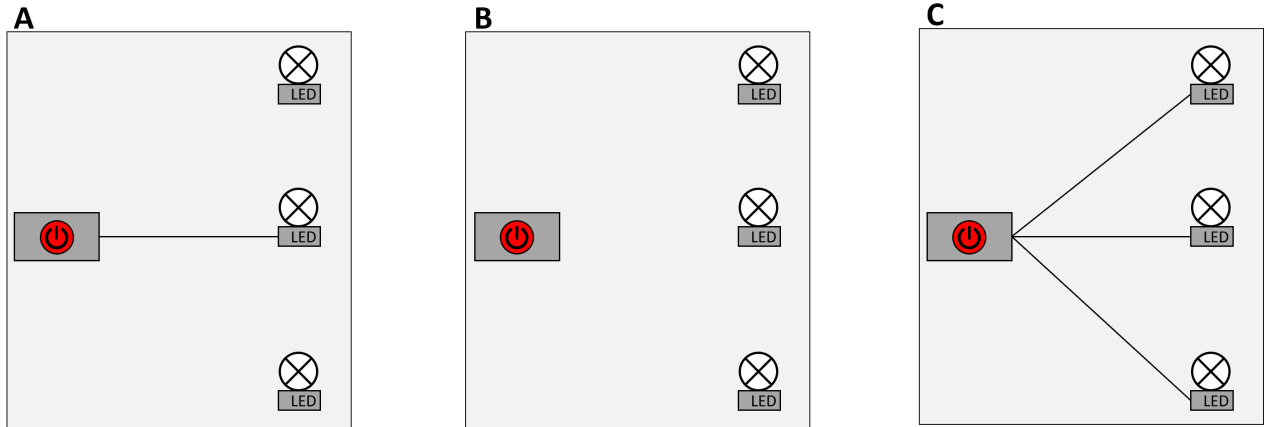

If you've studied the given information thoroughly, please answer the following questions:

If the red switch of box B is flipped from "off" to "on", how likely will this cause the middle LED to turn on?

Please use the scale below to provide your answer.

If the red switch of box C is flipped from "off" to "on", how likely will this cause the middle LED to turn on?

Please use the scale below to provide your answer.

If the red switch of box A is flipped from "off" to "on", how likely will this cause the middle LED to turn on?

Please use the scale below to provide your answer.

7.1.1 scenario

Please read the following information:

Below you see three independent electrical set-ups, A, B, and C. All consist of a "switch box" (left box with red button) that can be connected to up to three LED lights. Flipping a red switch from "off" to "on" causes the LEDs connected to the switch box to turn from "off" to "on".

Switch box A is not connected to any LED. Switch box B is connected to three LEDs. Switch box C is connected to one LED.

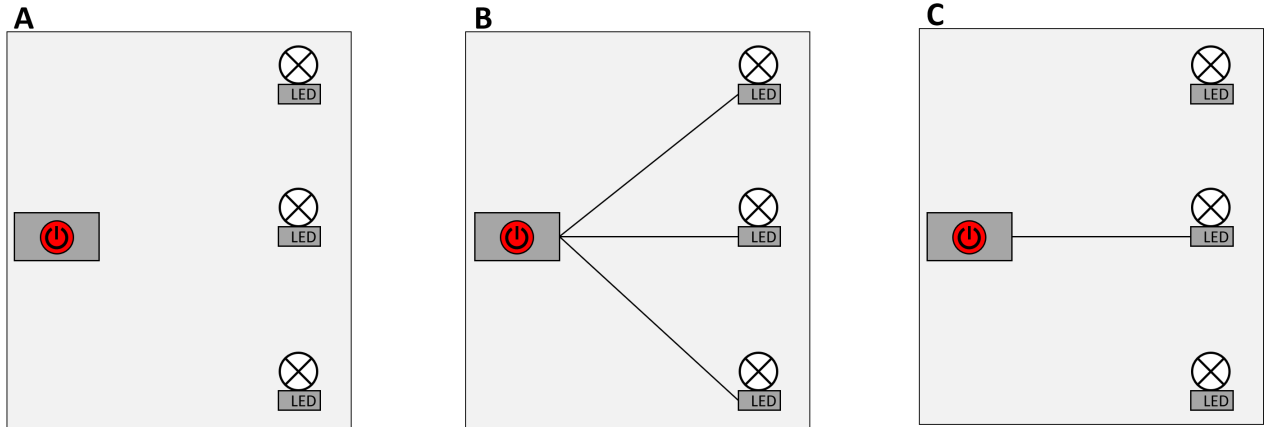

If you've studied the given information thoroughly, please answer the following questions:

If the red switch of box B is flipped from "off" to "on", how likely will this cause the middle LED to turn on?

Please use the scale below to provide your answer.

If the red switch of box C is flipped from "off" to "on", how likely will this cause the middle LED to turn on?

Please use the scale below to provide your answer.

If the red switch of box A is flipped from "off" to "on", how likely will this cause the middle LED to turn on?

Please use the scale below to provide your answer.

7.2.1 scenario

Please read the following information:

Below you see three independent electrical set-ups, A, B, and C. All consist of a "switch box" (left box with red button) that can be connected to up to three LED lights. Flipping a red switch from "off" to "on" causes the LEDs connected to the switch box to turn from "off" to "on".

Switch box A is not connected to any LED. Switch box B is connected to three LEDs. Switch box C is connected to one LED.

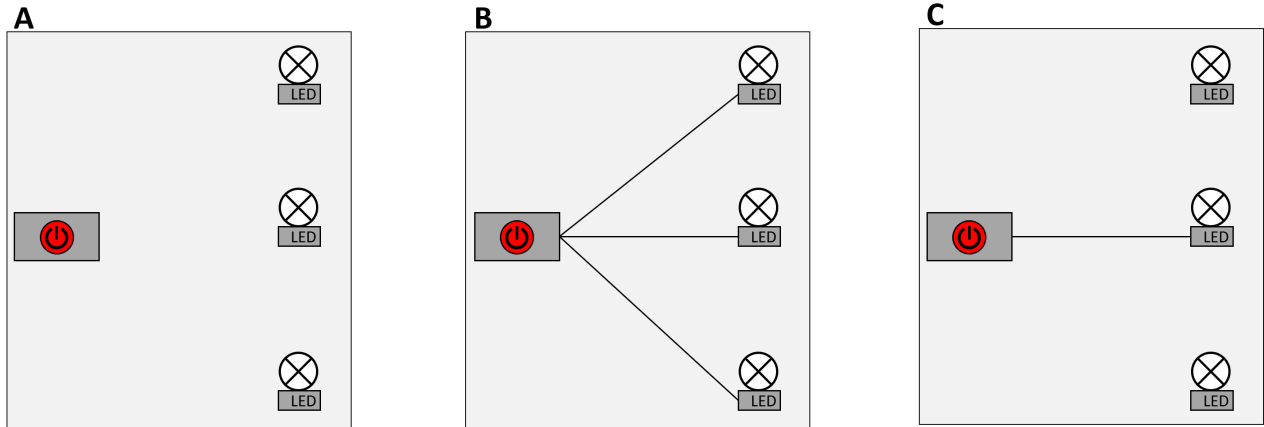

If you've studied the given information thoroughly, please answer the following questions:

If the red switch of box B is flipped from "off" to "on", how likely will this cause the middle LED to turn on?

Please use the scale below to provide your answer.

If the red switch of box A is flipped from "off" to "on", how likely will this cause the middle LED to turn on?

Please use the scale below to provide your answer.

If the red switch of box C is flipped from "off" to "on", how likely will this cause the middle LED to turn on?

Please use the scale below to provide your answer.

7.3.1 scenario

Please read the following information:

Below you see three independent electrical set-ups, A, B, and C. All consist of a "switch box" (left box with red button) that can be connected to up to three LED lights. Flipping a red switch from "off" to "on" causes the LEDs connected to the switch box to turn from "off" to "on".

Switch box A is not connected to any LED. Switch box B is connected to three LEDs. Switch box C is connected to one LED.

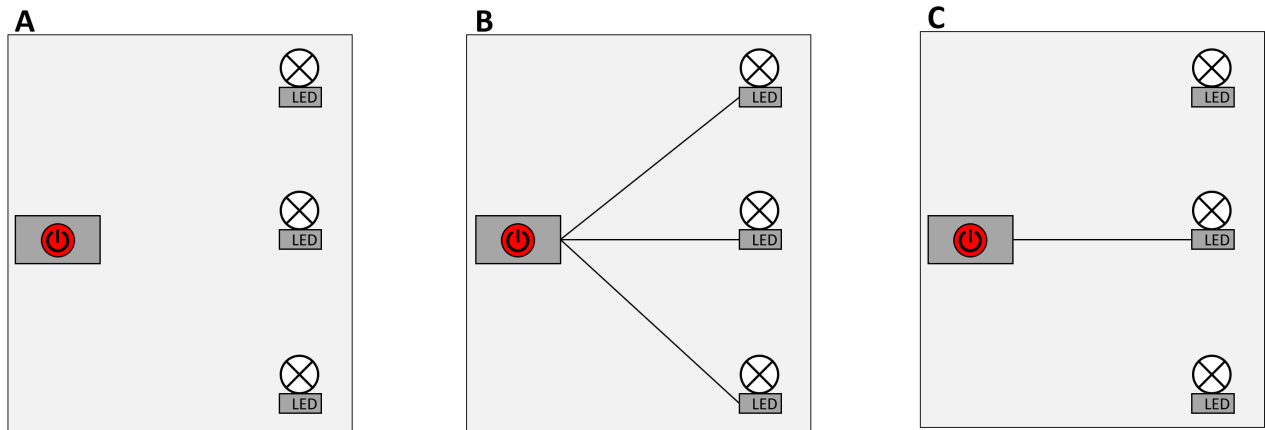

If you've studied the given information thoroughly, please answer the following questions:

If the red switch of box C is flipped from "off" to "on", how likely will this cause the middle LED to turn on?

Please use the scale below to provide your answer.

If the red switch of box B is flipped from "off" to "on", how likely will this cause the middle LED to turn on?

Please use the scale below to provide your answer.

If the red switch of box A is flipped from "off" to "on", how likely will this cause the middle LED to turn on?

Please use the scale below to provide your answer.

7.4.1 scenario

Please read the following information:

Below you see three independent electrical set-ups, A, B, and C. All consist of a "switch box" (left box with red button) that can be connected to up to three LED lights. Flipping a red switch from "off" to "on" causes the LEDs connected to the switch box to turn from "off" to "on".

Switch box A is not connected to any LED. Switch box B is connected to three LEDs. Switch box C is connected to one LED.

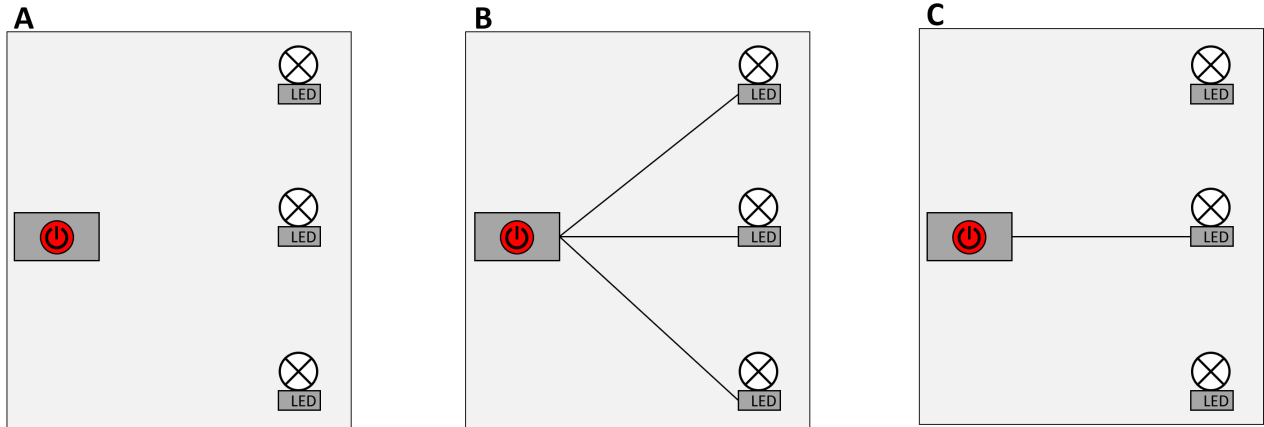

If you've studied the given information thoroughly, please answer the following questions:

If the red switch of box C is flipped from "off" to "on", how likely will this cause the middle LED to turn on?

Please use the scale below to provide your answer.

If the red switch of box A is flipped from "off" to "on", how likely will this cause the middle LED to turn on?

Please use the scale below to provide your answer.

If the red switch of box B is flipped from "off" to "on", how likely will this cause the middle LED to turn on?

Please use the scale below to provide your answer.

7.5.1 scenario

Please read the following information:

Below you see three independent electrical set-ups, A, B, and C. All consist of a "switch box" (left box with red button) that can be connected to up to three LED lights. Flipping a red switch from "off" to "on" causes the LEDs connected to the switch box to turn from "off" to "on".

Switch box A is not connected to any LED. Switch box B is connected to three LEDs. Switch box C is connected to one LED.

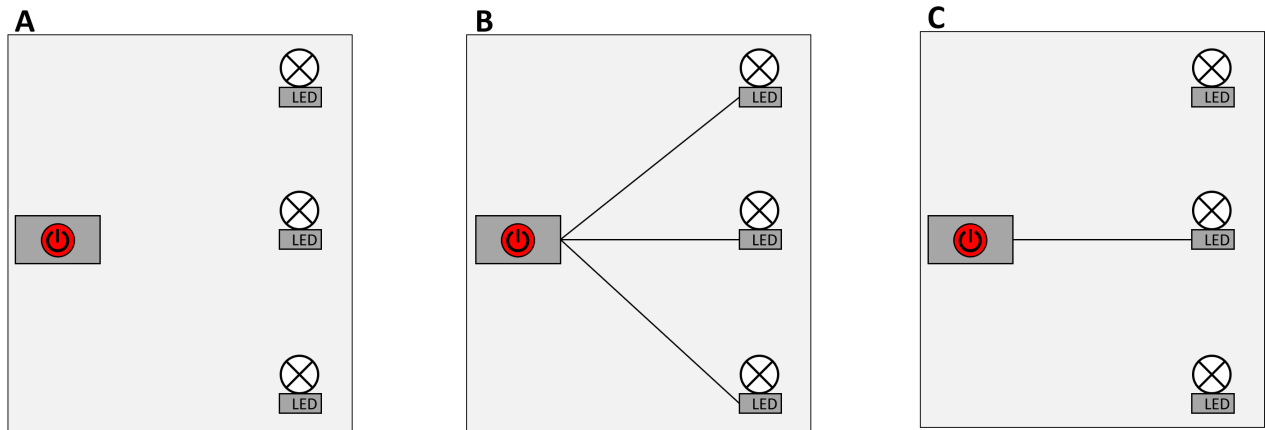

If you've studied the given information thoroughly, please answer the following questions:

If the red switch of box A is flipped from "off" to "on", how likely will this cause the middle LED to turn on?

Please use the scale below to provide your answer.

If the red switch of box B is flipped from "off" to "on", how likely will this cause the middle LED to turn on?

Please use the scale below to provide your answer.

If the red switch of box C is flipped from "off" to "on", how likely will this cause the middle LED to turn on?

Please use the scale below to provide your answer.

7.6.1 scenario

Please read the following information:

Below you see three independent electrical set-ups, A, B, and C. All consist of a "switch box" (left box with red button) that can be connected to up to three LED lights. Flipping a red switch from "off" to "on" causes the LEDs connected to the switch box to turn from "off" to "on".

Switch box A is not connected to any LED. Switch box B is connected to three LEDs. Switch box C is connected to one LED.

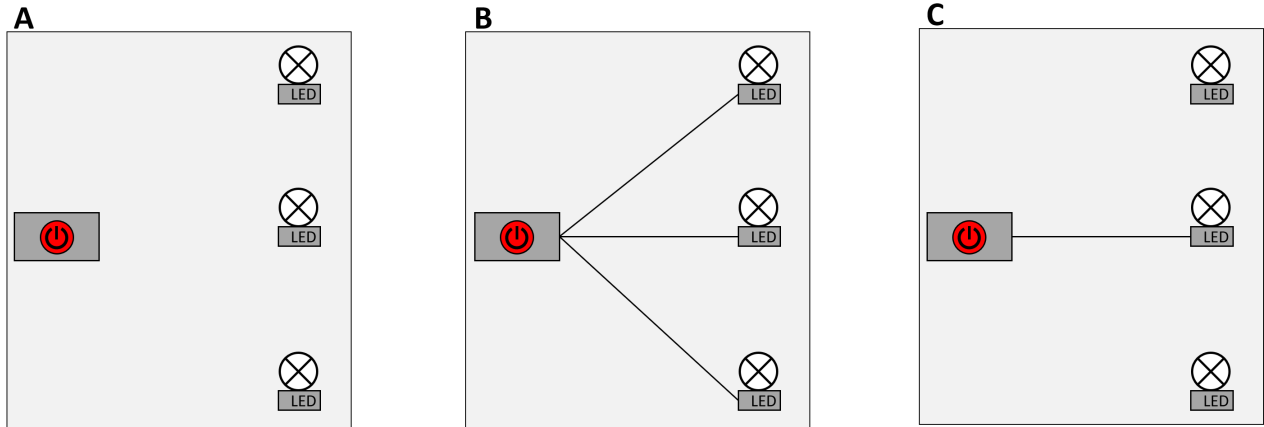

If you've studied the given information thoroughly, please answer the following questions:

If the red switch of box A is flipped from "off" to "on", how likely will this cause the middle LED to turn on?

Please use the scale below to provide your answer.

If the red switch of box C is flipped from "off" to "on", how likely will this cause the middle LED to turn on?

Please use the scale below to provide your answer.

If the red switch of box B is flipped from "off" to "on", how likely will this cause the middle LED to turn on?

Please use the scale below to provide your answer.

8.1.1 scenario

Please read the following information:

Below you see three independent electrical set-ups, A, B, and C. All consist of a "switch box" (left box with red button) that can be connected to up to three LED lights. Flipping a red switch from "off" to "on" causes the LEDs connected to the switch box to turn from "off" to "on".

Switch box A is not connected to any LED. Switch box B is connected to one LED. Switch box C is connected to three LEDs.

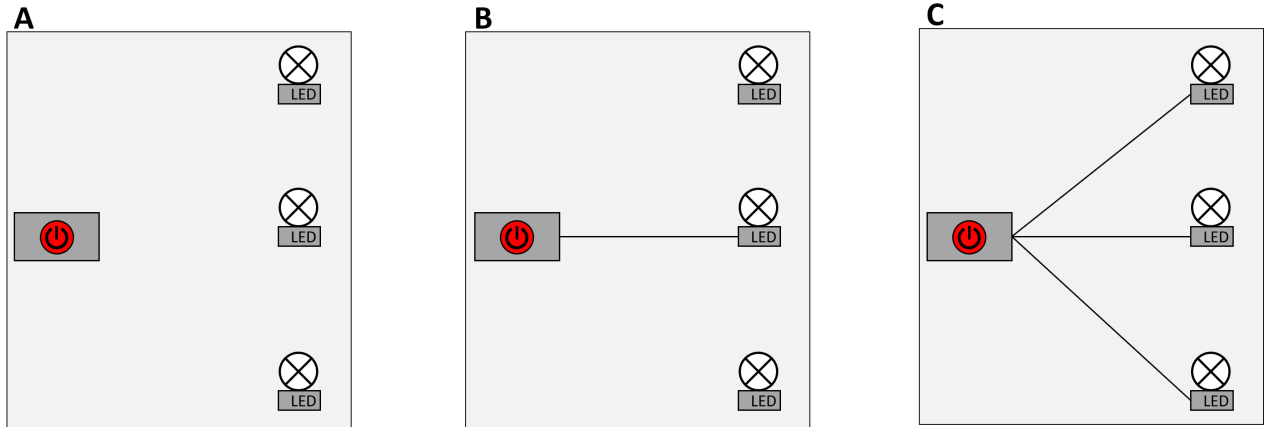

If you've studied the given information thoroughly, please answer the following questions:

If the red switch of box C is flipped from "off" to "on", how likely will this cause the middle LED to turn on?

Please use the scale below to provide your answer.

If the red switch of box B is flipped from "off" to "on", how likely will this cause the middle LED to turn on?

Please use the scale below to provide your answer.

If the red switch of box A is flipped from "off" to "on", how likely will this cause the middle LED to turn on?

Please use the scale below to provide your answer.

8.2.1 scenario

Please read the following information:

Below you see three independent electrical set-ups, A, B, and C. All consist of a "switch box" (left box with red button) that can be connected to up to three LED lights. Flipping a red switch from "off" to "on" causes the LEDs connected to the switch box to turn from "off" to "on".

Switch box A is not connected to any LED. Switch box B is connected to one LED. Switch box C is connected to three LEDs.

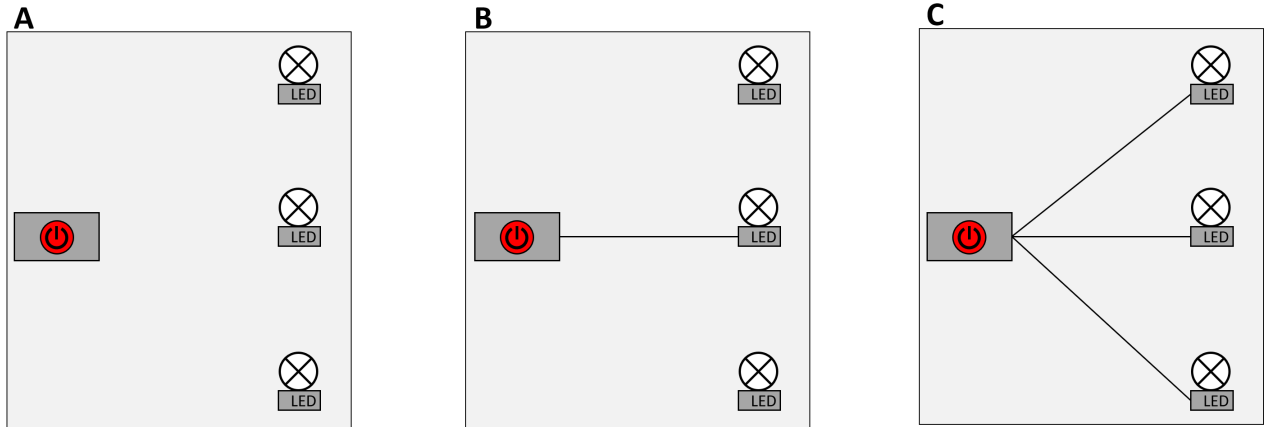

If you've studied the given information thoroughly, please answer the following questions:

If the red switch of box C is flipped from "off" to "on", how likely will this cause the middle LED to turn on?

Please use the scale below to provide your answer.

If the red switch of box A is flipped from "off" to "on", how likely will this cause the middle LED to turn on?

Please use the scale below to provide your answer.

If the red switch of box B is flipped from "off" to "on", how likely will this cause the middle LED to turn on?

Please use the scale below to provide your answer.

8.3.1 scenario

Please read the following information:

Below you see three independent electrical set-ups, A, B, and C. All consist of a "switch box" (left box with red button) that can be connected to up to three LED lights. Flipping a red switch from "off" to "on" causes the LEDs connected to the switch box to turn from "off" to "on".

Switch box A is not connected to any LED. Switch box B is connected to one LED. Switch box C is connected to three LEDs.

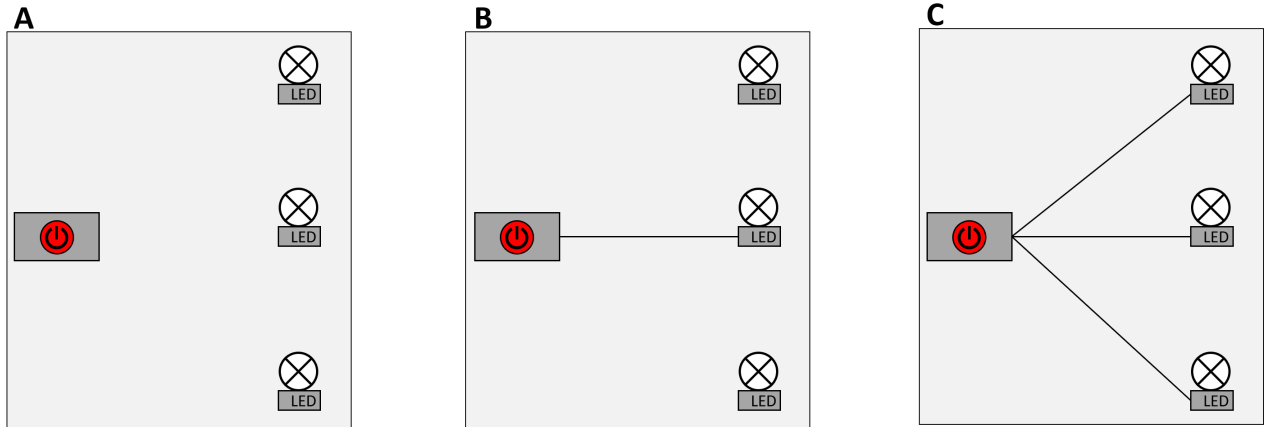

If you've studied the given information thoroughly, please answer the following questions:

If the red switch of box B is flipped from "off" to "on", how likely will this cause the middle LED to turn on?

Please use the scale below to provide your answer.

If the red switch of box C is flipped from "off" to "on", how likely will this cause the middle LED to turn on?

Please use the scale below to provide your answer.

If the red switch of box A is flipped from "off" to "on", how likely will this cause the middle LED to turn on?

Please use the scale below to provide your answer.

8.4.1 scenario

Please read the following information:

Below you see three independent electrical set-ups, A, B, and C. All consist of a "switch box" (left box with red button) that can be connected to up to three LED lights. Flipping a red switch from "off" to "on" causes the LEDs connected to the switch box to turn from "off" to "on".

Switch box A is not connected to any LED. Switch box B is connected to one LED. Switch box C is connected to three LEDs.

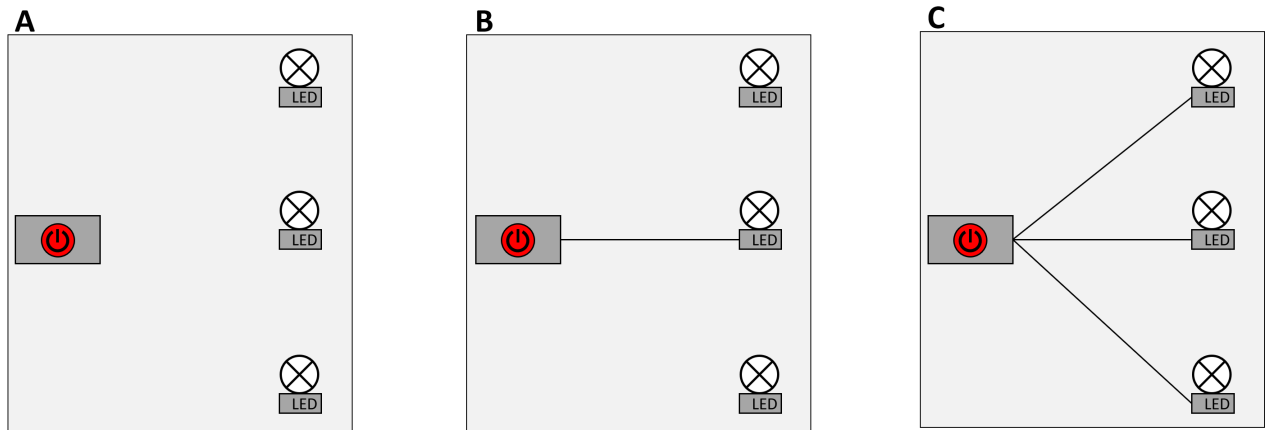

If you've studied the given information thoroughly, please answer the following questions:

If the red switch of box B is flipped from "off" to "on", how likely will this cause the middle LED to turn on?

Please use the scale below to provide your answer.

If the red switch of box A is flipped from "off" to "on", how likely will this cause the middle LED to turn on?

Please use the scale below to provide your answer.

If the red switch of box C is flipped from "off" to "on", how likely will this cause the middle LED to turn on?

Please use the scale below to provide your answer.

8.5.1 scenario

Please read the following information:

Below you see three independent electrical set-ups, A, B, and C. All consist of a "switch box" (left box with red button) that can be connected to up to three LED lights. Flipping a red switch from "off" to "on" causes the LEDs connected to the switch box to turn from "off" to "on".

Switch box A is not connected to any LED. Switch box B is connected to one LED. Switch box C is connected to three LEDs.

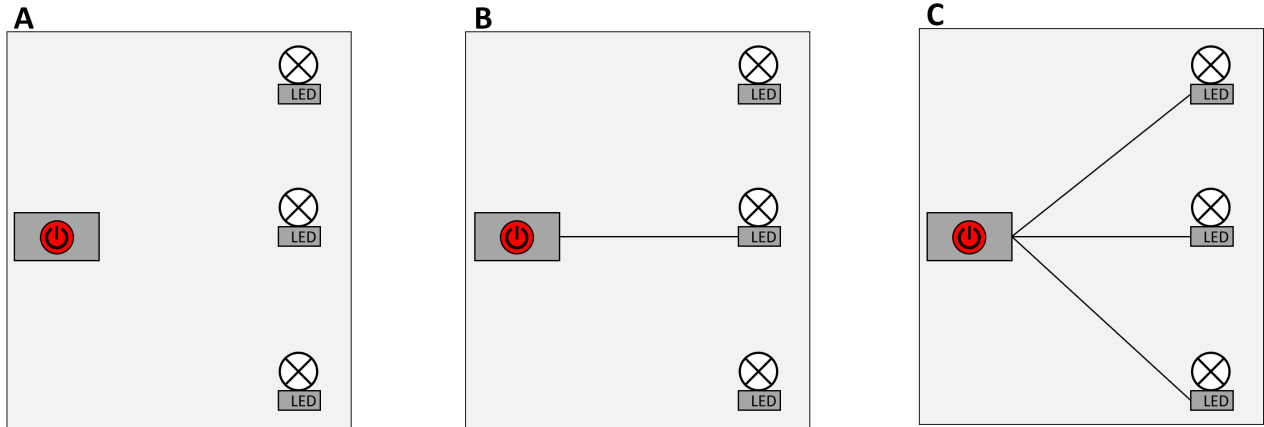

If you've studied the given information thoroughly, please answer the following questions:

If the red switch of box A is flipped from "off" to "on", how likely will this cause the middle LED to turn on?

Please use the scale below to provide your answer.

If the red switch of box C is flipped from "off" to "on", how likely will this cause the middle LED to turn on?

Please use the scale below to provide your answer.

If the red switch of box B is flipped from "off" to "on", how likely will this cause the middle LED to turn on?

Please use the scale below to provide your answer.

8.6.1 scenario

Please read the following information:

Below you see three independent electrical set-ups, A, B, and C. All consist of a "switch box" (left box with red button) that can be connected to up to three LED lights. Flipping a red switch from "off" to "on" causes the LEDs connected to the switch box to turn from "off" to "on".

Switch box A is not connected to any LED. Switch box B is connected to one LED. Switch box C is connected to three LEDs.

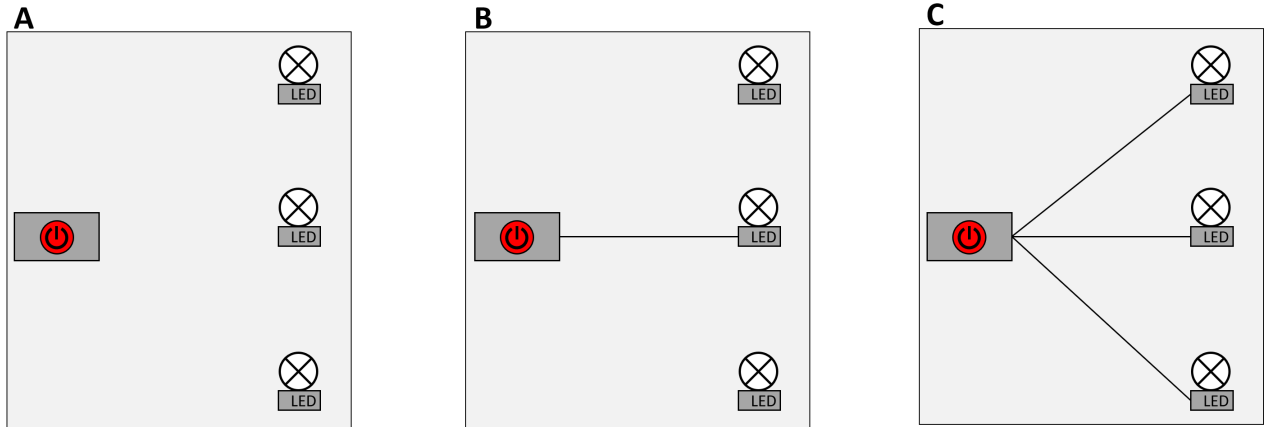

If you've studied the given information thoroughly, please answer the following questions:

If the red switch of box A is flipped from "off" to "on", how likely will this cause the middle LED to turn on?

Please use the scale below to provide your answer.

If the red switch of box B is flipped from "off" to "on", how likely will this cause the middle LED to turn on?

Please use the scale below to provide your answer.

If the red switch of box C is flipped from "off" to "on", how likely will this cause the middle LED to turn on?

Please use the scale below to provide your answer.

9 Demographie

Thank you very much for your effort, you are almost done with the survey. Please provide the following additional information:

Please indicate with which gender you identify.

- male
- female
- other
- prefer not to say

How old are you?

In the text field below you can report any errors that you came across during the study (e.g., technical issues, layout problems, spelling errors, errors in program logic and flow, etc.).

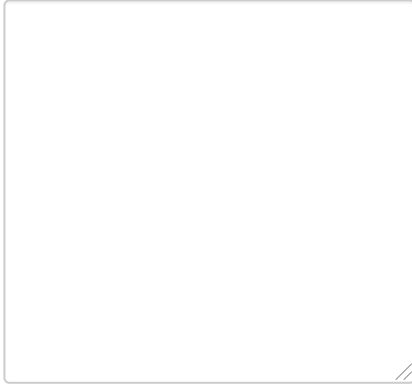

10 Endseite

Thank you for taking part in this study!

The aim of this experiment is to find out more about how people reason about causality. If you are interested in further details or if you have any questions or comments concerning the experiment, feel free to contact me (Simon Stephan) under sstepha1@uni-goettingen.de

To ensure you receive your reward, please click on the following link to return to the Prolific website:

[Link to Prolific](#)
